

Mayor
Michael L. Montandon

Council Members
William E. Robinson
Stephanie S. Smith
Shari Buck
Robert L. Eliason



City Manager
Gregory E. Rose

Your Community of Choice

Finance

2200 Civic Center Drive • North Las Vegas, Nevada 89030
Telephone: (702) 633-2438 • Fax: (702) 649-5077 • TDD: (800) 326-6868
www.cityofnorthlasvegas.com

June 20, 2007

**CITY OF NORTH LAS VEGAS
INVITATION TO BID NO. B-1279
STEEL STREETLIGHT POLES AND APPURTENANCES ANNUAL REQUIREMENTS**

Bids will be received in the Office of the City Clerk, 2200 Civic Center Drive, North Las Vegas, Nevada, 89030 until **2:00 p.m. on Tuesday, July 10, 2007** and will be publicly opened and read shortly thereafter in the Office of the Purchasing Manager at the previous address in City Hall.

A **pre-proposal conference** will be held on **Tuesday, June 26, 2007 at 2:00 p.m. in the City Council Chambers** located at 2200 Civic Center Drive, North Las Vegas NV 89030 to discuss and answer questions concerning the project.

Bid documents can be picked up in the Purchasing & Risk Management Office, Monday through Thursday, 8:00 a.m. - 4:00 p.m. at the address above. Bids may also be accessed at www.rfpdepot.com, www.demandstar.com or under the Purchasing/Risk Management Web page www.cityofnorthlasvegas.com.

The City reserves the right to reject any and all bids, waive any informality or technicality or to otherwise accept bids deemed in the best interest of the City.

Renee' Swanson
Buyer

**Published Review Journal
June 21, 2007**

INSTRUCTIONS TO BIDDERS

1. PROJECT SPECIFICATIONS:

The Bidder/Contractor shall not take advantage of any apparent error or omission in the Plans or Specifications. In the event the Contractor discovers such an error or omission, he shall immediately notify the Purchasing Manager. The Purchasing Manager will then make such corrections and interpretations as may be deemed necessary for fulfilling the intent of the Specifications and Plans.

2. EXPLANATION TO BIDDERS:

Any explanations desired by Bidders regarding the meaning or interpretation of specifications must be requested in writing and with sufficient time allowed for a reply to reach them before submission of their bids. Oral explanations given before the award of the contract will not be binding. Any written interpretation made will be furnished to all BIDDERS and its receipt by the BIDDER will be acknowledged.

Interpretation of the meaning of the plans, specifications or other pre-bid documents will not be binding if presented to any BIDDER orally. Every request for such interpretation should be in writing addressed to **Renee' Swanson, Buyer**, swansonr@cityofnorthlasvegas.com, or in writing to Attn: Renee' Swanson, City of North Las Vegas – Purchasing/Finance, 2200 Civic Center Drive, North Las Vegas, NV 89030. Any and all such interpretations and any supplemental instructions deemed necessary will be in the form of written addenda to the specifications which, if issued, will be mailed to all known perspective BIDDERS. Failure of any BIDDER to receive any such addendum or interpretation shall not relieve such BIDDER from any obligation under this bid as submitted. All addenda so issued shall become part of the Contract Documents.

3. BIDDER'S UNDERSTANDING:

At the time of the opening of bids, each Bidder will be required to have considered all pertinent licensing, laws and regulations, and to have read and to be thoroughly familiar with the Bidding Documents (including all addenda). The failure or omission of any BIDDER to examine any form, instrument or document shall in no way relieve any BIDDER from any obligation in respect of his bid.

It is further agreed that the lump sum prices may be increased to cover additional work ordered but not shown on the Bidding Documents. Similarly, they may be decreased to cover deletion of work so ordered.

4. **PREPARATION OF BIDS:**

Bids must be prepared on the bid forms provided herein. Bidders may request withdrawal of a posted sealed bid prior to the bid opening time provided the request is made to the City Clerk's Office. No bid may be withdrawn for a period of sixty days after the bid opening.

5. **LICENSES:**

All BIDDERS must have appropriate licenses in accordance with the laws of the State of Nevada, prior to submission of bids for this project. All bids received in violation of this law shall be rejected and returned to the BIDDER.

6. **SUBMISSION OF BIDS:**

Bid proposals may be submitted as follows:

A. When possible, each proposal must be submitted in a sealed envelope of adequate size, show the BIDDER'S name and address and be marked "Bid Proposal", with the name of the proposal, to clearly indicate its contents.

B. When sent by mail, the sealed proposal must be addressed to the City Clerk, City of North Las Vegas, 2200 Civic Center Drive, North Las Vegas, Nevada 89030 in whose Office the bids are to be received.

C. All proposals shall be filled prior to the time and at the place specified in the "Invitation to Bid". Proposals received after the time for opening of bids will be returned To the BIDDER unopened.

7. **PUBLIC OPENING:**

Proposals will be opened and read publicly at the time and place indicated in the "Invitation to Bid". The BIDDERS, their authorized agents and public are invited to be present.

No responsibility will attach to any OWNER official for the pre-opening of, or the failure to open, a bid not properly addressed or identified.

8. **PRE QUALIFICATION OF BIDDERS:**

The low BIDDER may be required to file prior to award of contract, an experience questionnaire and confidential financial statement which must be a complete report of the financial resources and liabilities, equipment, past record, personnel or organization and experience.

9. **CONSIDERATION OF BIDS:**

After the bids are opened and read, they will be compared on the basis of the summation of the products of the approximate quantities shown in the bid schedule. The results of such comparisons will be made available to the public as soon as feasible. In the event of a discrepancy between the unit price and extended figure, the unit price shall govern. The right is reserved to reject any or all proposals, to waive technicalities, to advertise for new proposals, or to proceed to do the work otherwise, if in the judgment of the OWNER the best interest of the City will be promoted.

10. **EQUIPMENT SUBSTITUTIONS**

In preparing these specifications, the Engineer has named those products, which to its knowledge meet the specifications and are equivalent in construction, functional efficiency, and durability.

Wherever catalog numbers and specific brands or trade names followed by the designation "or equal" are used in conjunction with a specific piece of equipment in these specifications, they are used to establish the standards of quality and utility required.

11. **AWARD OF CONTRACT:**

The award of contract, if it be awarded, will be to the lowest responsive and responsible BIDDER whose proposal complies with all the requirements prescribed. The award, if made, will be within sixty (60) days after opening proposals. The successful BIDDER will be notified, by letter mailed to the address shown on his offer, that his bid has been accepted.

The LOWEST BID is the bid submitted with the lowest summation of ALL bid schedules, additive alternates, and deductions.

12. **EQUAL EMPLOYMENT OPPORTUNITY:**

Attention of BIDDERS is particularly called to the requirement for insuring that employees and applicants for employment are not discriminated against because of their race, color, creed or national origin.

13. **PROVISIONS PROVIDED BY LAW DEEMED INSERTED:**

Each and every provision and clause required by law to be inserted in the contract shall be read and enforced as though it were included herein, and if through mistake or otherwise any such provision is not inserted, or is not correctly inserted, then upon the application of either party the contract forthwith shall be physically amended to make such insertion or correction.

The BIDDER'S attention is directed to the fact that all applicable City, County, State and Federal laws, and the rules and regulations of all authorities having jurisdiction over the project shall apply to the contract throughout and they will be deemed to be included in the contract the same as though herein written out in full.

14. **TERMS OF THE AGREEMENT:**

This AGREEMENT commences upon the date it is approved by the CITY and shall end three (3) years thereafter with the option to renew for two one-year periods.

15. **CANCELATION OF CONTRACT:**

The OWNER reserves the right to cancel the award or execution of any contract at any time before the Purchase Order has been issued without any liability or claims thereof against the OWNER.

16. **METHOD OF AWARD**

Award will be made to the lowest responsive and responsible Bidder.

17. **DELIVERY REQUIREMENTS - F.O.B. DESTINATION POINT**

All prices shall be F.O.B. Destination to 1628 W. Brooks Avenue, North Las Vegas, NV 89030, Attn: Mike Edwards. All prices shall include storage, delivery and unloading.

18. **NOTICE OF DELIVERY**

City shall be given **five (5) calendar days notice prior to delivery.** Notify Mike Edwards at telephone number (702) 633-2732.

19. **NOTICE OF AWARD**

Award of contracts will be by "Purchase Order" which together with the signed Bid Proposal will be used as the Contract document.

20. **WORKMEN'S COMPENSATION INSURANCE:**

This section not used.

21. **ASSIGNMENT:**

It is agreed that the successful bidder will not assign, transfer, convey or otherwise dispose of the contract without permission of the City.

22. **TAXES:**

The City is exempt from State retail and Federal Excise Tax. The bid price must be net, exclusive of taxes.

23. **INDEMNITY:**

The successful bidder agrees to defend, indemnify, and hold the City harmless from any and all causes of action or claims arising out of or related to the bidder's performance on this project.

24. **EXCEPTIONS:**

Each BIDDER will list on a separate sheet of paper any exceptions to specifications and attach it to their bid.

25. **WARRANTY:**

Warranty period against defects in material or workmanship will be for a minimum of thirty-six (36) months on all parts, systems, attachments and/or accessories affixed to the originally acquired unit.

26. **NEW EQUIPMENT**

The Bidder shall guarantee that the units submitted shall be new and the latest and most improved model of current productions, and shall be of first quality as to workmanship and materials used in said units. All notifications shall be made at the factory.

New equipment is defined as equipment that is made up completely of unused genuine original parts. Equipment shall not have been operated for any purpose other than routine operational testing. Demonstrator equipment does not meet this definition and is not acceptable.

All equipment listed shall be fully operable upon delivery. Operational condition will be defined as per the manufacturer's current specifications.

27. **ADDITIONAL UNITS**

The City reserves the right to purchase additional units in accordance with Nevada Revised Statute 332.

28. **ESCALATION:**

Prices may be increased by not more than 3.5% in each subsequent model production year.

**BID B-1279 STEEL STREET LIGHT POLES AND APPURTENANCES ANNUAL
REQUIREMENTS
TECHNICAL SPECIFICATIONS**

Standards for street lighting shall be as specified in the Uniform Standard Drawings (USD) for the Clark County, Nevada area available at the internet home site of the Regional Transportation Commission of Southern Nevada at www.rtcsonthernnevada.com. Drawings of the USD 314, 315, 316, 317, 318, 319, and 321 and approved equal to Ameron concrete pole standard for North Las Vegas, NV shall apply unless specified otherwise in these specifications

The lighting pole shaft shall consist of four (4) anchor bolts with eight (8) washers and eight (8) nuts, pole cap, hand hole cover with steel backing plate, anchor bolt covers and all necessary hardware to install the peripheral items in conjunction with the pole shaft installation in the field to the satisfaction of the Engineer. The luminaire arm with associated hardware shall be furnished separately.

POLE ASSEMBLY

The pole shaft shall be of round cross section with minimum outer diameter of eight (8) inches at the base and shall uniformly decrease in diameter at the rate of 0.14 inches per foot of length. The pole shafts may be multi-sided with a minimum of 20 sides if the standard retains the appearance of a round unit.

The shaft shall be formed from not more than three (3) pieces of sheet steel. Only one (1) piece of sheet steel shall be used for each section.

All welds shall be continuous. A maximum of two (2) circumferential welds and one (1) longitudinal weld will be permitted in assembling the shaft. Where the sections are butt-welded together, the welded seams of adjacent sections shall be placed to form a continuous weld from the base to top of standard. Butt joints shall be reinforced in the corresponding gage by three (3) inch (75 millimeters wide tapered sleeves of the same composition as the steel in the standard. The sleeves shall be centered at the joint and have the same taper as the standard so that the outside of the sleeve is in full contact throughout its length in circumference. Welding shall be done by AWS certified welders and shall conform to the best accepted practice.

All surplus weld material or protrusions shall be ground off smooth to present an indiscernible joint. Ground joints shall maintain the strength of the original metal. Exposed welds, except fillet welds, shall be ground flush with the base metal.

Pole shafts shall be straight, with a permissive variation not to exceed $\frac{3}{4}$ inch measured at the midpoint of 30-foot poles. Standards shall be round with an out-of-round variation not to exceed $\frac{1}{8}$ inch (3 millimeters).

Sheet steel used in manufacturing process of the poles shall have an initial minimum yield of 48,000 psi, or which after forming or cold rolling shall develop a minimum of 48,000 psi, in accordance with ASTM Designation E 8, and shall be of not less than No. 11 gage (0.119 inch) or No. 7 gage (0.179 inch).

The pole base plate shall be a 1-inch thick for No. 11 gage standards and 1-1/8 inch thick No. 7 gage pole shafts. Both base plates shall be 11-1/2 inches square and shall conform to ASTM Designation A 27, Grade 65-35 cast steel or ASTM Designation A 36 steel plate or A 283, Grade D steel plate slotted to accommodate four (4) 1-1/8 inch anchor rods equally spaced on an eleven (11) inch bolt circle. All exposed edges of the base assembly shall be finished smooth and all exposed corners of such plates shall be neatly rounded to 1/8 inch radius unless otherwise shown on the plans. The pole shaft shall telescope through the base plate and shall be secured by two continuous welds, one on the inside at the bottom of the plate and the other on the outside on top of the plate.

The luminaire pipe arm shall be formed with a single radius bend from two (2) inch schedule 40 pipe 8 feet in length, conforming to ASTM Designation A 53. A minimum straight portion of five (5) inches shall be provided to attach the luminaire. The shaft end of the arm shall have weather-resistant steel fitting, welded in place. The fitting shall be shaped to lock on the shaft fitting by gravity and shall be secured by a minimum of one cap screw.

When twin luminaire arms are specified, they may be tapered steel or schedule 40, 2-inch pipe arms eight (8) feet in length, conforming to ASTM Designation A 570, Grade A may be used.

For tapered mast arms, the luminaire end shall consist of a welded two (2) inch schedule 40, 10-1/2 inch pipe length pipe with a 7-1/2 inch exposed tenon, and the opposite end shall have a welded three bolt weather resistant steel fitting as called for on the Street Light Standard Drawing No. 314. The bolts shall be high strength conforming to ASTM Designation A 325 high strength bolts.

The handhole shall be four (4) inch by six and one-half (6-1/2) inch reinforced frame and slip-resistant type cover located eight (8) inches (200 millimeters) from the base plate. The cover shall include a steel clamping bar with one weather and vandal resistant 1/4-inch hexagonal socket head screw.

The anchor-bolt cover shall be two-piece ferrous metal design and hot-dip galvanized to match the pole shaft. It shall cover the base plate completely and shall be firmly secured. The base cover shall be nine (9) inches in height.

Pole assemblies, anchor-bolt and handhole covers, luminaire arms, pole caps and associated hardware shall be hot-dip galvanized in conformance with ASTM Designation A123. The Engineer shall reject galvanized materials that have a striped or uneven appearance. Minor flaws in the appearance of galvanized components shall be cause for rejection by the owner.

The steel used in standards shall be tested in accordance with ASTM Designation A 370 paragraph 13.1. The supplier of the standards shall furnish certified notarized test reports showing the yield strength after fabrication of material used in the shaft and subsequent standards shall conform to this certification. At the discretion of the Engineer random samples may be selected of the finished product for testing purposes and test shall be carried out and reports furnished at no additional cost.

The standard shall sustain a horizontal test load of 500 pounds applied eighteen (18) inches from the top of the shaft in any direction without failure of any component part, and with a deflection of not more than 7-1/2 % of the pole shaft length as measured from point of load application to the base plate. This deflection includes a maximum allowance of 1/2 inch for testing and permanent set.

Luminaire brackets or mast arms and related pole attachment devices shall sustain a vertical load of 100 pounds applied within three (3) inches of the luminaire end of the support with the support attached to a rigid structure. The vertical deflection shall not exceed 5-1/2 % of the bracket or mast arm length. The luminaire brackets or mast arms and related pole attachment devices shall sustain a transverse horizontal load of fifty (50) pounds applied within three (3) inches of the luminaire end of the support with the support attached to a rigid structure. The horizontal deflection shall not exceed 10 % of the bracket or mast arm length, and the pole attached devices shall not develop any looseness within the specified loading range.

ANCHOR BOLTS

Anchor bolts shall conform to ASTM Designation A 576, Grad C-1035 for minimum yield strength of 48,000 psi and shall be provided with two nuts and two washers of 2-1/2 inch minimum OD. The anchor bolts and all nuts and washers shall be completely galvanized by the hot-dip process conforming to ASTM Designation A123. After galvanized the bolt threads shall accept galvanized standard nuts without requiring tools or causing removal of protective coating.

All anchor bolts for No. 7 gage and No. 11 gage streetlight poles shall be 1-1/8 inch by 40 inches by 4 inches the upper eight (8) inches of the anchor bolts shall be threaded.

**BID B-1279 STEEL STREET LIGHT POLES AND APPURTENANCES
ANNUAL REQUIREMENTS**

TECHNICAL DRAWINGS

NOTES:

1. PLACE BOTTOM PLATE WITH SPACER PLATE ON LEVELING NUTS ON ANCHOR BOLTS AND FASTEN IN PLACE.
2. TOP PLATE SHALL BE FURNISHED BY LIGHT POLE FABRICATOR AS LIGHT POLE BASE PLATE WITH DIMENSIONS AS SHOWN IN PLAN VIEW.
3. ERECT LIGHT POLE AND SECURE WITH 1 IN. DIA. HIGH STRENGTH BOLTS. BOLTS SHALL BE INSTALLED IN THE SLOTS SO THAT THE BOLT SHANKS ARE IN CONTACT WITH THE PLATES.
4. ANCHOR BOLT SIZES SHALL BE IN ACCORDANCE WITH DRAWING NO. 317.
5. ALL STEEL PLATE ASSEMBLIES SHALL BE HOT-DIPPED GALVANIZED AFTER FABRICATION.
6. ALL SLIP NUTS, BOLTS, AND WASHERS SHALL BE ELECTRO-PLATED CADMIUM IN ACCORDANCE WITH ASTM A-165, TYPE TS.
7. ALL CONTACT AREAS OF PLATES SHALL BE FREE OF GALVANIZING BEADS OR RUNS.
8. SLIP BOLTS SHALL BE TORQUED TO 150 FOOT-POUNDS OR 1800 INCH-POUNDS.
9. GROUTING WITH CONCRETE CAP SHALL BE DONE AFTER LIGHT POLE HAS BEEN LOCATED IN FINAL POSITION.
10. SAFETY BASES SHALL BE USED IN SPECIAL CASES AS DETERMINED BY THE ENGINEER.

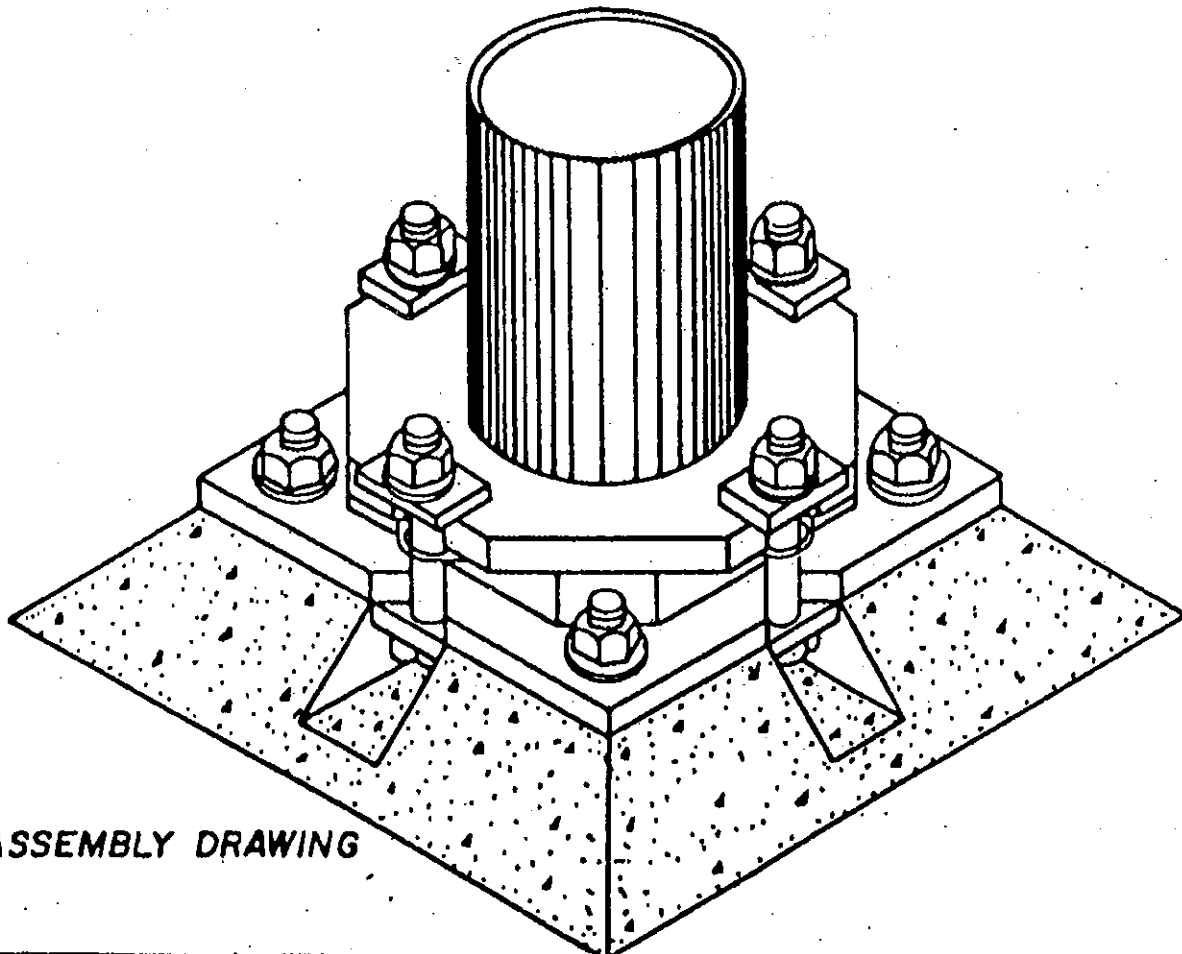

ASSEMBLY DRAWING

SPECIFICATION REFERENCE		UNIFORM STANDARD DRAWINGS CLARK COUNTY AREA SAFETY BASE FOR STREET LIGHTING STANDARD	
506	STEEL STRUCTURES		
623	TRAFFIC SIGNALS & STREET LIGHTING		
715	GALVANIZING		
DATE	DWG NO. 3	PAGE NO.	

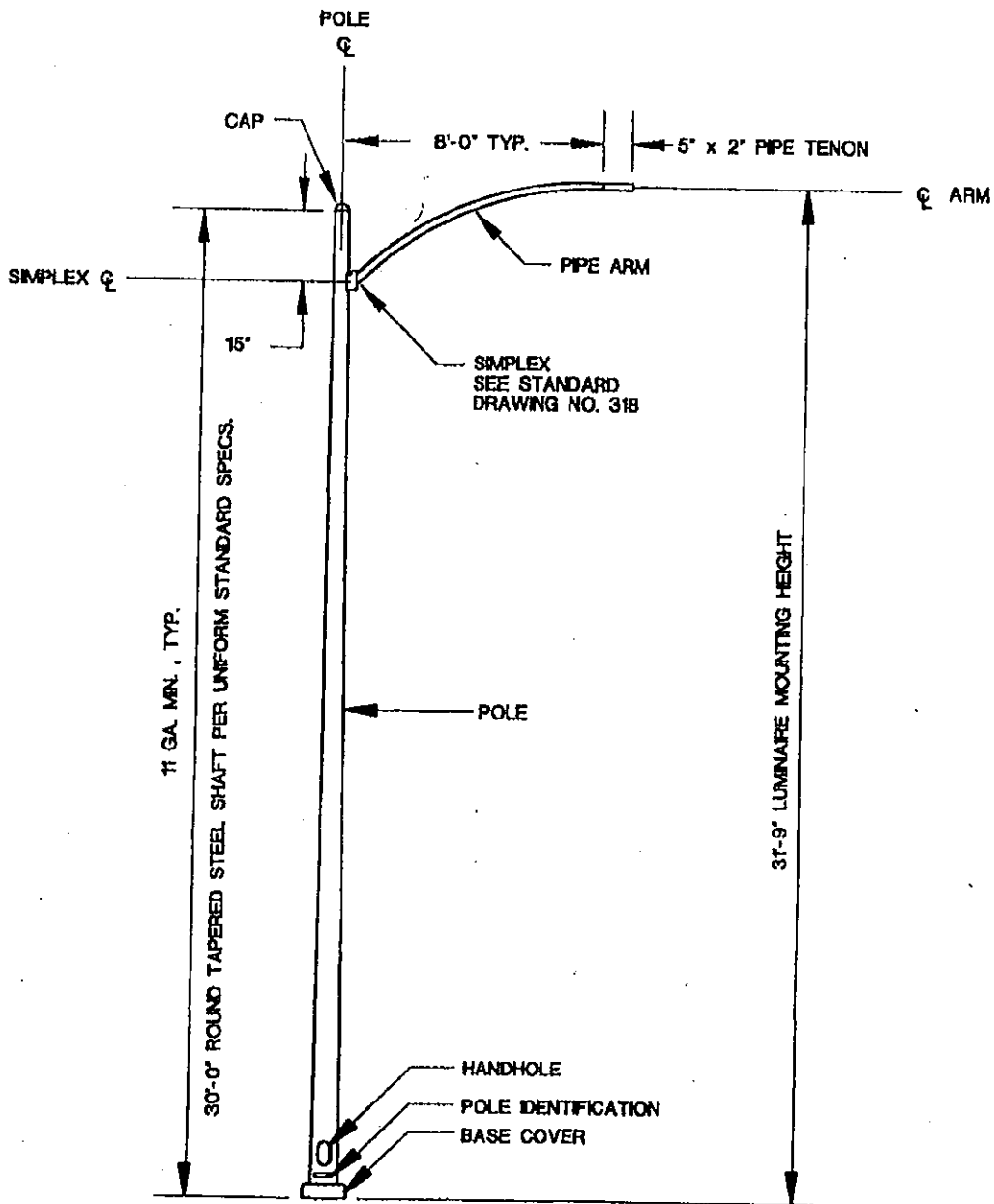

NOTES:

1. SEE GENERAL NOTES STANDARD DRAWING NO. 313.
2. SEE STANDARD DRAWING NO. 319 FOR DETAIL OF POLE BASE.
3. SEE STANDARD DRAWING NO. 318 FOR DETAIL OF POLE CAP.

SPECIFICATION REFERENCE		UNIFORM STANDARD DRAWINGS CLARK COUNTY AREA		
506	STEEL STRUCTURES	STREETLIGHT STANDARD WITH 2" PIPE ARM		
623	TRAFFIC SIGNALS & STREETLIGHTING			
715	GALVANIZING			
		DATE 12-12-98	DWG. NO. 314	PAGE NO. 74

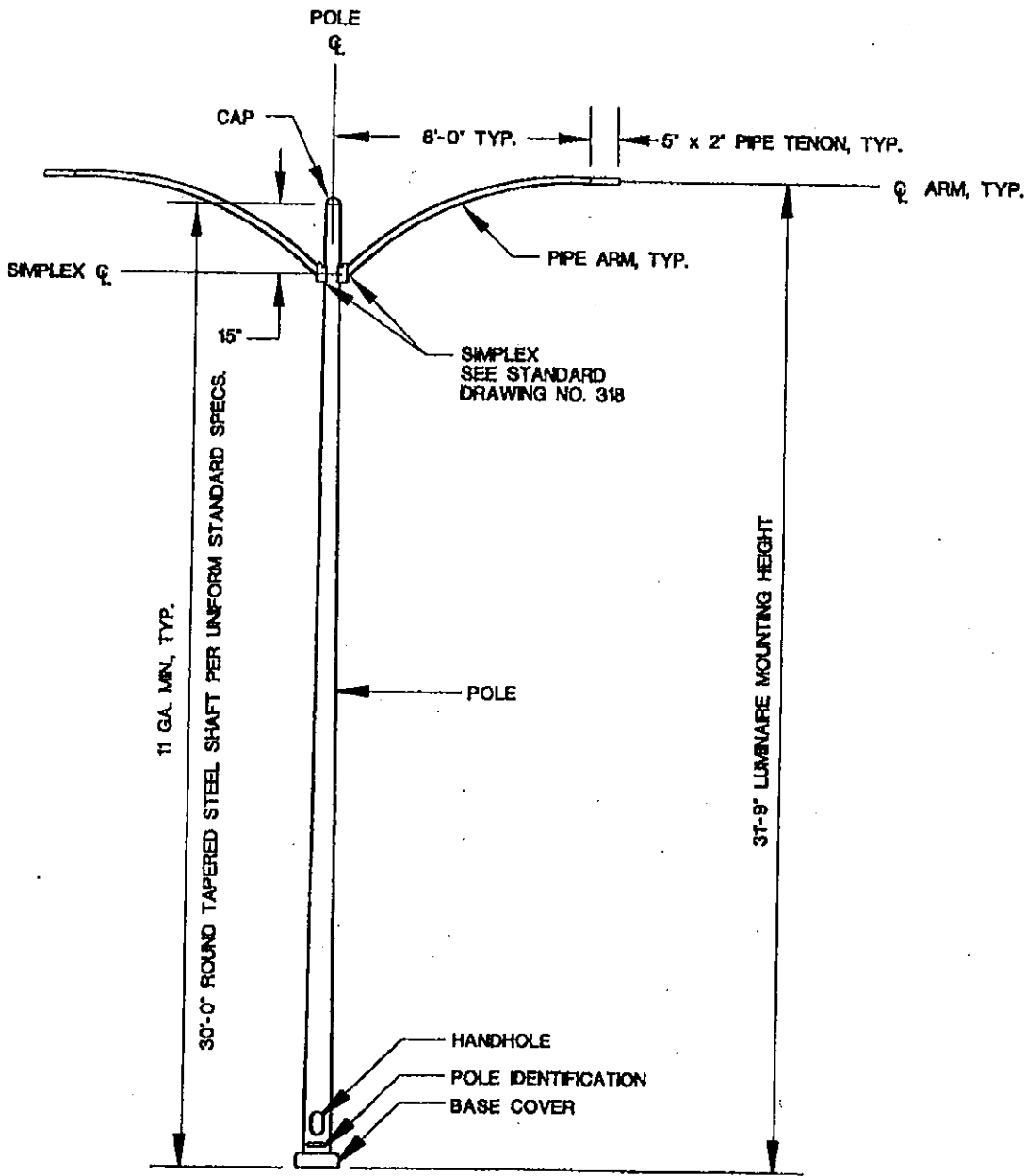

NOTES:

1. SEE GENERAL NOTES STANDARD DRAWING NO. 313.
2. SEE STANDARD DRAWING NO. 319 FOR DETAIL OF POLE BASE.
3. SEE STANDARD DRAWING NO. 318 FOR DETAIL OF POLE CAP.

SPECIFICATION REFERENCE		UNIFORM STANDARD DRAWINGS CLARK COUNTY AREA		
506	STEEL STRUCTURES	STREETLIGHT STANDARD WITH DOUBLE 2" PIPE ARM		
623	TRAFFIC SIGNALS & STREETLIGHTING			
715	GALVANIZING			
		DATE 12-12-96	DWG. NO. 315	PAGE NO. 75

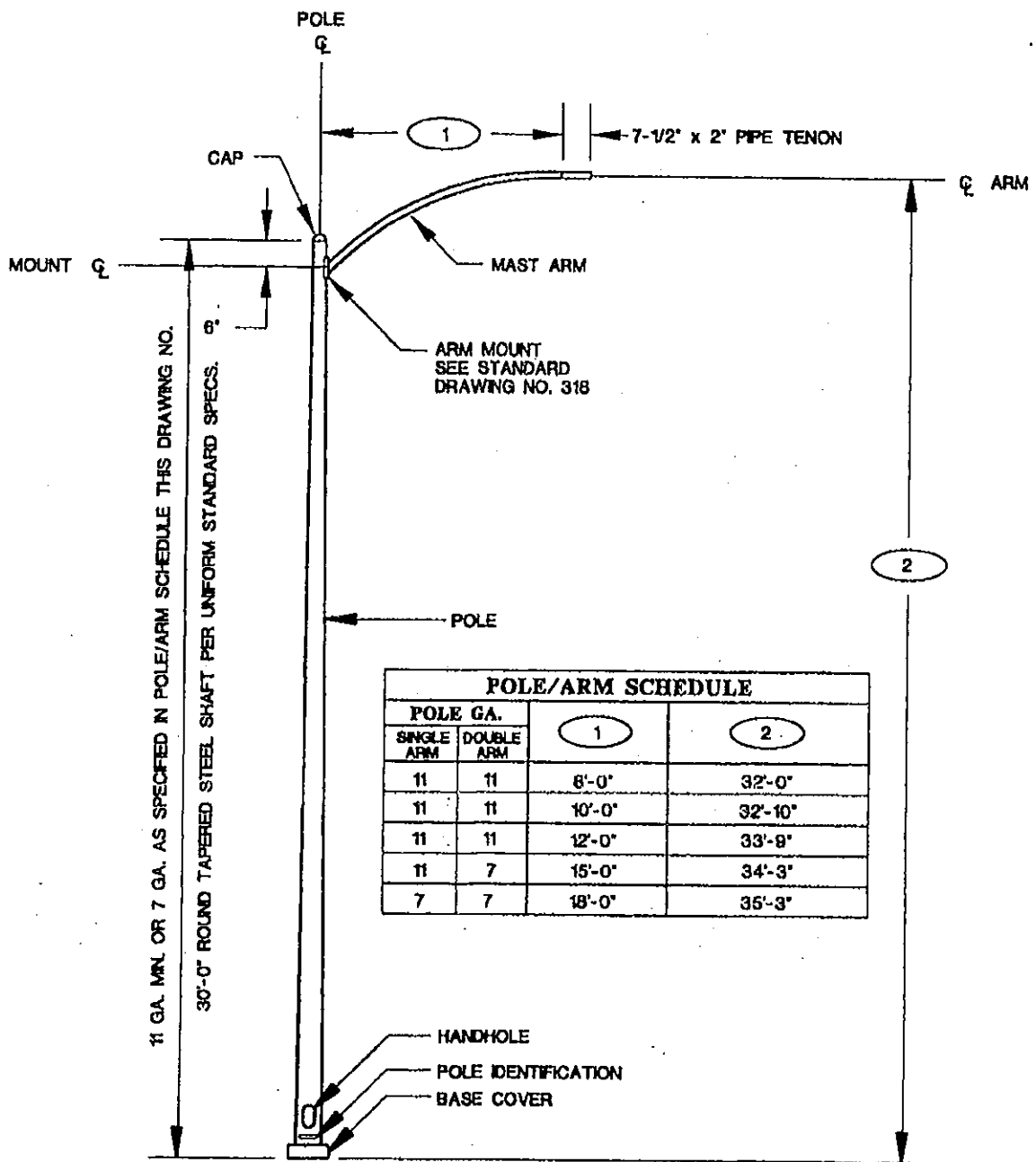

NOTES:

1. SEE GENERAL NOTES STANDARD DRAWING NO. 313.
2. SEE STANDARD DRAWING NO. 319 FOR DETAIL OF POLE BASE.
3. SEE STANDARD DRAWING NO. 318 FOR DETAIL OF POLE CAP.

SPECIFICATION REFERENCE		UNIFORM STANDARD DRAWINGS CLARK COUNTY AREA	
506	STEEL STRUCTURES	STREETLIGHT STANDARD WITH TAPERED MAST ARM	
623	TRAFFIC SIGNALS & STREETLIGHTING		
715	GALVANIZING		
		DATE 12-12-98	DWG. NO. 316
		PAGE NO. 76	

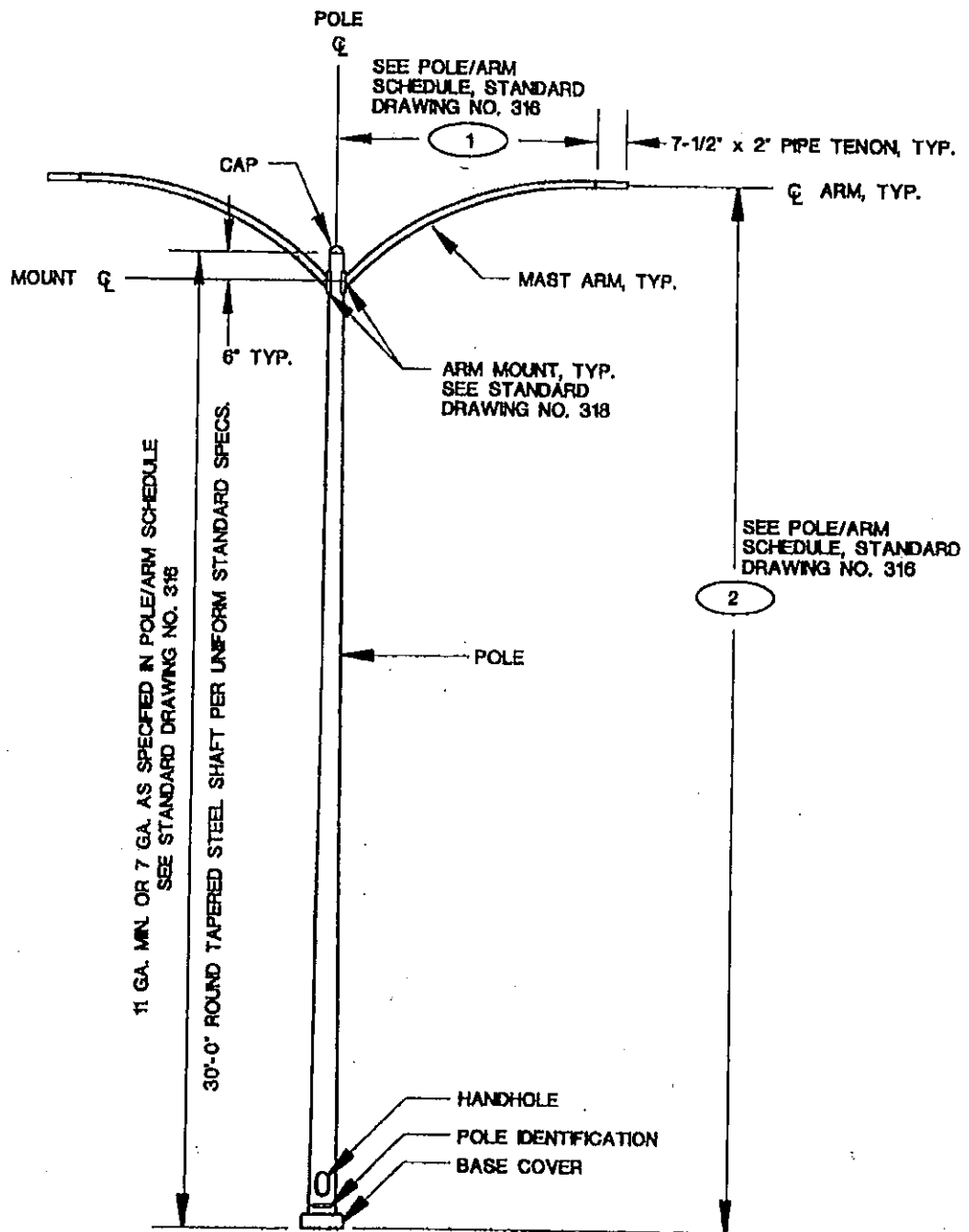

NOTES:

1. SEE GENERAL NOTES STANDARD DRAWING NO. 313.
2. SEE STANDARD DRAWING NO. 319 FOR DETAIL OF POLE BASE.
3. SEE STANDARD DRAWING NO. 318 FOR DETAIL OF POLE CAP.

SPECIFICATION REFERENCE		UNIFORM STANDARD DRAWINGS CLARK COUNTY AREA	
506	STEEL STRUCTURES	STREETLIGHT STANDARD WITH DOUBLE TAPERED MAST ARM	
623	TRAFFIC SIGNALS & STREETLIGHTING		
715	GALVANIZING		
		DATE 12-12-96	DWG. NO. 317
		PAGE NO. 77	

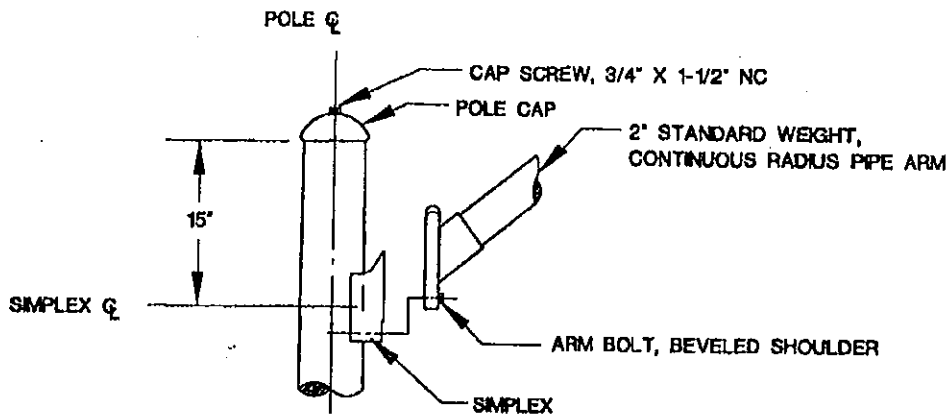

PIPE ARM

NOTE:

SEE GENERAL NOTES
STANDARD DRAWING NO. 313.

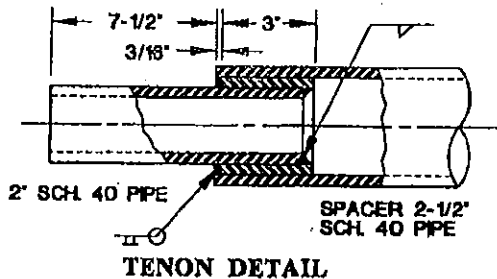
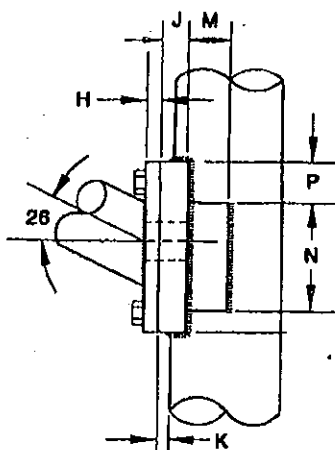
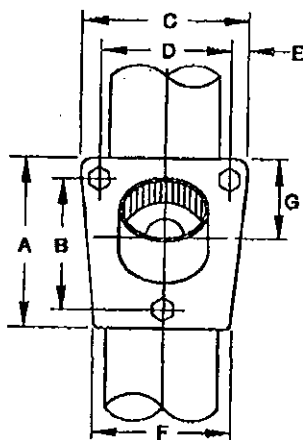
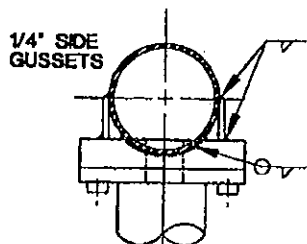
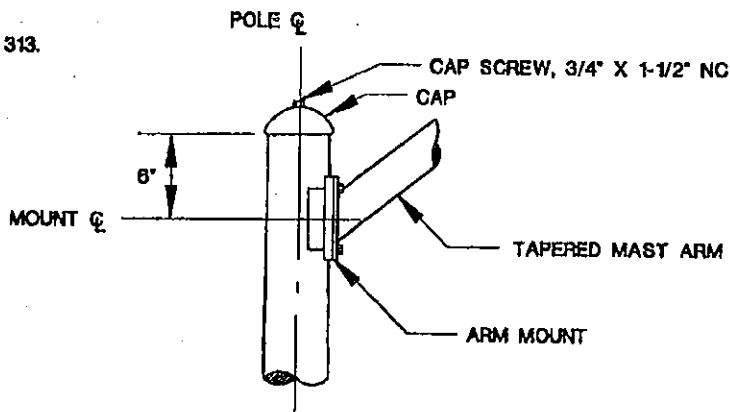

MAST ARM	A	B	C	D	E	F	G
8'-15' INCL.	7-1/2"	5-3/4"	6-3/8"	4-5/8"	7/8"	5"	3-3/8"
15'-18' INCL.	9"	7"	8"	6"	T	6"	4"

MAST ARM	H	J	K	L	M	N	P
8'-15' INCL.	1/2"	T	5/16"	5/8"-10X1-1/2"	1-1/2"	5"	1-5/8"
15'-18' INCL.	3/4"	T	5/16"	3/4"-10X1-3/4"	2"	6"	1-3/4"

MAST ARM AND DETAILS

SPECIFICATION REFERENCE		UNIFORM STANDARD DRAWINGS CLARK COUNTY AREA	
506	STEEL STRUCTURES	POLE TOP AND ARM MOUNTING DETAILS	
623	TRAFFIC SIGNALS & STREETLIGHTING		
715	GALVANIZING		
		DATE 12-12-96	DWG. NO. 318
		PAGE NO. 78	

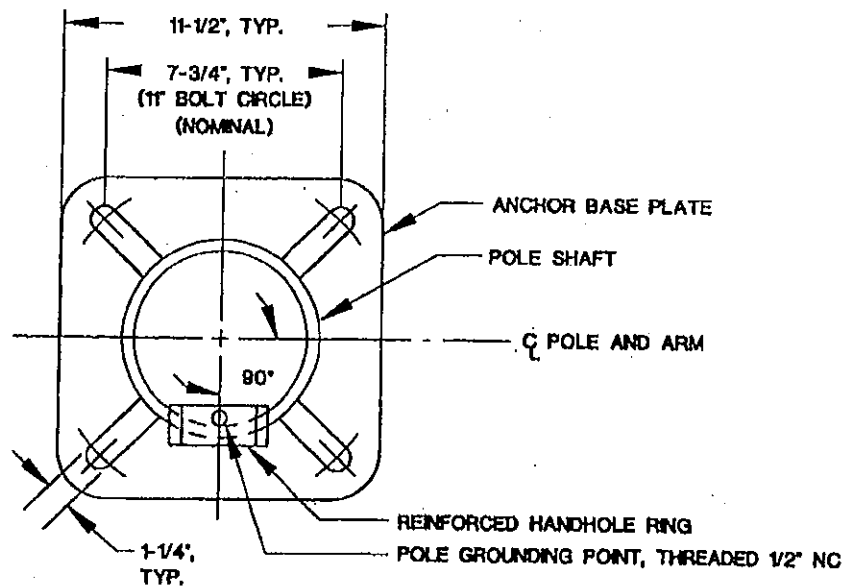
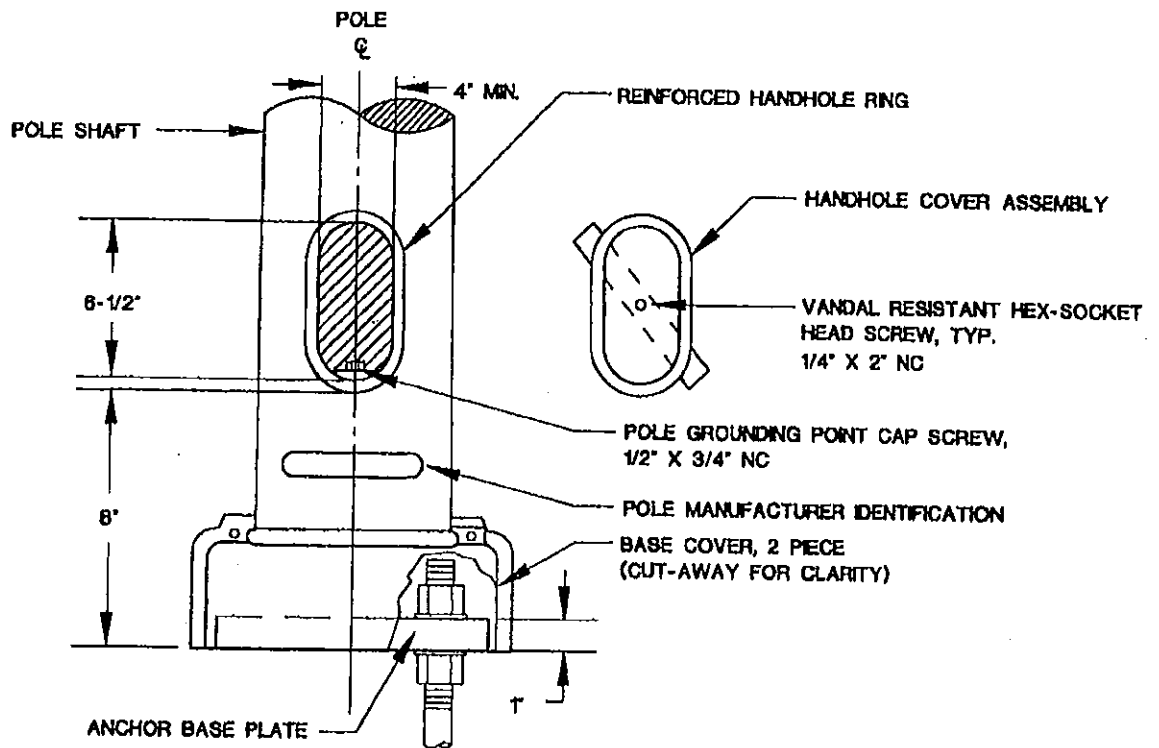

NOTES:

1. SEE GENERAL NOTES STANDARD DRAWING NO. 313
2. HANDHOLE SHALL FACE AWAY FROM ONCOMING TRAFFIC.

SPECIFICATION REFERENCE		UNIFORM STANDARD DRAWINGS CLARK COUNTY AREA	
508	STEEL STRUCTURES	LOWER POLE DETAILS FOR PIPE AND MAST ARM POLES	
623	TRAFFIC SIGNALS & STREETLIGHTING		
715	GALVANIZING		
		DATE 12-12-96	DWG. NO. 319
		PAGE NO. 79	

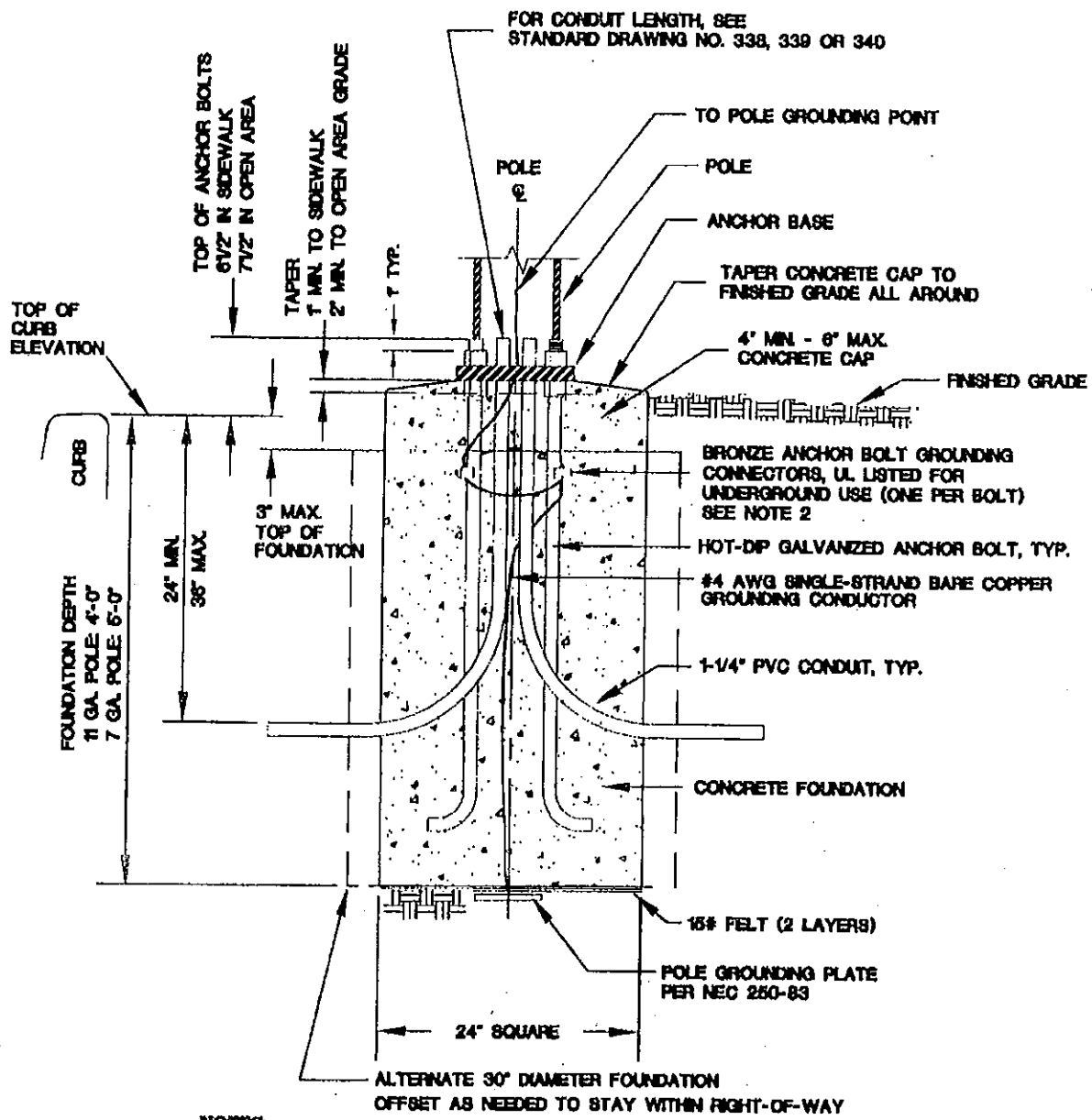

NOTES:

1. SEE GENERAL NOTES STANDARD DRAWING NO. 313
2. CONTINUOUS BARE COPPER GROUNDING CONDUCTOR SHALL BE LOOPED AROUND ANCHOR BOLTS ONE TIME AND CONNECTED TO EACH ANCHOR BOLT BEFORE CONTINUING DOWN TO THE POLE GROUNDING PLATE.
3. FOUNDATION CAP SHALL BE CONCRETE OR GROUT AS DESIGNATED BY THE ENTITY ENGINEER.

SPECIFICATION REFERENCE		UNIFORM STANDARD DRAWINGS CLARK COUNTY AREA		
501	PORTLAND CEMENT CONCRETE			
823	TRAFFIC SIGNALS & STREETLIGHTING	LIGHTING STANDARD FOUNDATION		
		DATE 7-8-04	DWG. NO. 321	PAGE NO. 81

**BID B-1279 STEEL STREET LIGHT POLES AND APPURTENANCES
ANNUAL REQUIREMENTS**

BID B-1279 BID SUBMITTAL SHEETS

ITEM NO.	DESCRIPTION	QTY	UNIT OF MEASURE	UNIT COST	EXTENDED COST
1	30' Street Lighting, Standard, 11 Gauge, w/12' Mast Arm per attached Uniform Standard Drawings Clark County Area DWG No. 316	6	Each		
	Mfg.				
	Part#				
2	30' Street Lighting, Standard, 7 Gauge, w/15' Mast Arm per attached Uniform Standard Drawings Clark County Area DWG No. 316	6	Each		
	Mfg.				
	Part#				
3	30' Street Lighting, Standard, 11 Gauge, Without Mast Arm per attached Uniform Standard Drawings Clark County Area DWG No. 317	6	Each		
	Mfg.				
	Part#				
4	30' Street Lighting, Standard, 7 Gauge, Without Mast Arm per attached Uniform Standard Drawings Clark County Area DWG No. 317	6	EACH		
	Mfg.				
	Part#				
5	30' Street Lighting, Standard, 11 Gauge Single Mast Arm per attached Uniform Standard Drawings Clark County Area DWG No. 316. For Breakaway Street Light Pole See Attached Drawing #3 For Pole Base Detail for above Pole				
	Mfg.				
	Part#				

CONTINUED ON NEXT PAGE

**BID B-1279 STEEL STREET LIGHT POLES AND APPURTENANCES
ANNUAL REQUIREMENTS**

BID B-1279 BID SUBMITTAL SHEETS (Continued)

ITEM NO.	DESCRIPTION	QTY	UNIT OF MEASURE	UNIT COST	EXTENDED COST
6	30' Street Lighting, Standard, 11 Gauge, Double Mast Arm per attached Uniform Standard Drawings Clark County Area DWG No. 317 For Breakaway Street Light Pole see attached drawing #3 for pole base	1	Each		
	Mfg.				
	Part#				
7	30' Street Lighting, Standard, 7 Gauge, with 15' Mast Arm per attached Uniform Standard Drawings Clark County Area DWG No. 317. See attached drawing #3 for breakaway street light pole for pole base	6	Each		
	Mfg.				
	Part#				
8	30' Street Lighting, Standard 11 Gauge, 8' 2" Pipe Arm per attached Uniform Standard Drawings Clark County Area DWG No. 314	60	Each		
	Mfg.				
	Part#				
9	30' Street Lighting, Standard 11 Gauge, 8' 0" 2" Pipe Arm per attached Uniform Standard Drawings Clark County Area DWG No. 315	6	Each		
	Mfg.				
	Part#				
10	Cover, Hand hole, Oval per attached drawing #319	60	Each		
	Mfg.				
	Part#				

CONTINUED ON NEXT PAGE

**BID B-1279 STEEL STREET LIGHT POLES AND APPURTENANCES
ANNUAL REQUIREMENTS**

BID B-1279 BID SUBMITTAL SHEETS (Continued)

ITEM NO.	DESCRIPTION	QTY	UNIT OF MEASURE	UNIT COST	EXTENDED COST
11	Cover, Handhole, Rectangular 4" x 6 1/2"	25	Each		
	Mfg.				
	Part#				
12	Mast Arm, 15' Tapered, Three Bolts, per attached Uniform Standard Drawings Clark County Area DWG No. 316 & 318	1	Each		
	Mfg.				
	Part#				
13	Mast Arm, 12' Tapered, Three Bolts, per attached Uniform Standard Drawings Clark County Area DWG No. 316 & 318	1	Each		
	Mfg.				
	Part#				
14	Mast Arm 10' Tapered, Three Bolts, per attached Uniform Standard Drawings Clark County Area DWG No. 316 & 318	1	Each		
	Mfg.				
	Part#				
15	Mast Arm 8' Tapered, Three Bolts, per attached Uniform Standard Drawings Clark County Area DWG No. 316 & 318	1	Each		
	Mfg.				
	Part#				

CONTINUED ON NEXT PAGE

**BID B-1279 STEEL STREET LIGHT POLES AND APPURTENANCES
ANNUAL REQUIREMENTS**

BID B-1279 BID SUBMITTAL SHEETS (Continued)

ITEM NO.	DESCRIPTION	QTY	UNIT OF MEASURE	UNIT COST	EXTENDED COST
16	8' Pipe Arm, per attached Uniform Standard Drawings Clark County Area DWG No. 314	1	Each		
	Mfg.				
	Part#				

TOTAL BID AMOUNT \$ _____

DELIVERY TIME: _____

PAYMENT TERMS: _____ PERCENT _____ DAYS

IF OUT OF STATE, LIST THE TOLL FREE NUMBER OR THE COLLECT CALLING NUMBER FOR ORDER PLACEMENT: _____

EXCEPTIONS TO BID:

*The Bidder must list on a separate sheet of paper any exceptions to the conditions of this Invitation to Bid. This sheet must be labeled, "**Exceptions to Bid Conditions**", and must be attached to the Bid Proposal. If no exceptions are stated, it will be understood that all terms, conditions and specifications will be complied with, without exception. **ANY EXCEPTIONS MAY BE CONSIDERED MATERIAL AND CAUSE FOR REJECTION.***

_____		_____
SIGNATURE OF BIDDER		PRINTED NAMED
_____		_____
NAME OF COMPANY		ADDRESS OF FIRM
_____		_____
Phone Number of Bidder		City, State and Zip Code
_____		_____
Fax Number	Date	E-mail address

**B-1279 STEEL STREET LIGHT POLES AND APPURTENANCES
ANNUAL REQUIREMENTS**

SAMPLE CONTRACT

(Sample)
**AGREEMENT BETWEEN CITY OF NORTH LAS VEGAS
AND
[insert legal name of other party-]**

THIS AGREEMENT BETWEEN THE CITY OF NORTH LAS VEGAS AND [insert legal name of other party-] (this "AGREEMENT") is executed this ___ day of ___, 200__ by and between the City of North Las Vegas, a Nevada municipal corporation (the "CITY") and [insert legal name of other party, a [insert name of state and type of entity the other party is-] (the "SERVICES PROVIDER").

RECITALS

1. The City desires to purchase Traffic Poles, Signal Mast Arms and Cover Bases Annual Requirements (the "PROJECT");

2. The Services Provider is experienced in Traffic Poles, Signal Mast Arms and Cover Bases Annual Requirements (the "SERVICES");

3. The City desires to have the Services Provider perform [all][a portion] of the Project, and the Services Provider agrees to such performance, upon the terms and conditions described in this Agreement;

NOW, THEREFORE, upon good and valuable consideration, the receipt and sufficiency of which is hereby acknowledged, the City and the Services Provider agree to the following terms, conditions and covenants:

**SECTION ONE
RESPONSIBILITY OF SERVICES PROVIDER**

In addition to any other obligations of Services Provider under this Agreement, the Services Provider has the following responsibilities:

1.1. The Services Provider shall be responsible for the professional quality, technical accuracy, timely completion, and coordination of all services furnished by the Services Provider, by Services Provider's subcontractors, and by any of the principals, officers, employees and agents of Services Provider and any subcontractor under this Agreement.

1.2. The Services Provider hereby designates [insert name of Services Provider's contact person] as the employee, agent or representative of Services Provider who is (1) responsible for making sure the Scope of Work (as defined below) is performed in its entirety on time and on budget, and (2) the point-of-contact for the City for all matters concerning the Project, and (3) authorized to make all decisions and take all actions necessary to pay, perform and deliver all obligations of Services Provider pursuant to the terms and conditions of this Agreement (the "RESPONSIBLE PERSON"). All of the responsibilities of the Services Provider specified by this Agreement shall be performed by the

Responsible Person, or by the Services Provider's associates, employees and subcontractors under the personal supervision of the Responsible Person. If the Responsible Person becomes unable to serve in the capacity of Responsible Person for any reason, the Services Provider shall notify the City in writing of such inability, and shall, within four (4) calendar days thereafter, nominate a replacement for City approval, in its reasonable discretion, who has an equivalent amount of experience performing the same type of Services as required for the Project. The Services Provider shall promptly replace any Responsible Person deemed by the City to be unacceptable with a Responsible Person who is acceptable to the City.

1.3. The Services Provider shall not reproduce, display, or otherwise use the name, logo or any other intellectual property, including without limitation, any trade name, mark, patent or copyright, of the City without the City's prior written consent.

1.4. The Services Provider shall not send or publish to any third party any correspondence related to the Project or this Agreement without the City's prior written approval thereof.

1.5. The Services Provider, and its agents, employees, and subcontractors will cooperate with the City in the performance of this Agreement and will be available for consultation with the City at all reasonable times during normal business hours or at all other times with twenty-four hours advance notice.

1.6. The Services Provider shall perform all of its obligations under this Agreement in compliance with the Project Schedule attached hereto and incorporated herein as Exhibit A, as such may be modified or amended from time to time by mutual agreement of the City and the Services Provider (the "PROJECT SCHEDULE"). **[Attach the task by task completion timeline (whether in a Critical Path format or other method) as Exhibit A]** The Services Provider shall commence the Project on _____, 200__, and complete the Project by _____, 200__ **[See #8-CTW]**.

A. At any time that the Services Provider falls behind schedule, the Services Provider shall promptly notify the City of such fact and, at its own expense, shall promptly take all actions necessary to come back into compliance with the Project Schedule, including without limitation, paying for and providing overtime labor; provided however, that if the Services Provider believes that a delay in the Project Schedule is due solely to the negligence or intentional misconduct of the City, the Services Provider may, by written notice, request that the City grant additional time equal to the amount of time lost due to the City's conduct, and the City may grant such additional time in its reasonable discretion. In the event of a Force Majeure Event (as defined below), the Services Provider may also, by written notice, request additional time equal to the number of days the Force Majeure Event was occurring.

B. No additional compensation shall be paid to Services Provider for additional costs or delay due to the negligence or intentional acts of Services Provider or any of its employees, agents, contractors or subcontractors, or any of the officers, employees, or agents of any of them.

1.7. The Services Provider shall perform all of its obligations under this Agreement in compliance with the budget set forth in Exhibit B attached hereto and incorporated herein, as it may be amended from time to time by mutual written agreement of the City and the Services Provider (the "BUDGET"). **[Attach the task by task cost breakdown (whether in spreadsheet format or otherwise) as Exhibit B]** If the Services Provider determines that the Project is over Budget in its entirety or in any line item of the Budget, the Services Provider shall promptly notify the City of such fact and, at its own expense, shall promptly take all actions necessary to come back into compliance with the Budget, including without limitation, paying the amount of such overage from the Services Provider's own funds; provided however, that if the Services Provider believes that an overage in all or a portion of the Budget is due solely to the negligence or intentional misconduct of the City, the Services Provider may, by written notice, request that the City grant additional funds equal to the amount of the overage created due to the City's conduct, and the City may grant such additional funds in its reasonable discretion. In the event of a Force Majeure Event, the Services Provider may also, by written notice, request additional funds equal to the amount of funds directly attributable to the Force Majeure Event.

1.8. The Services Provider shall pay, perform and deliver all obligations of Services Provider set forth in this Agreement, including without limitation those obligations set forth in Exhibit C attached hereto and incorporated herein, as it may be amended by mutual agreement of the City and the Services Provider from time to time, and all related additional or incidental tasks necessary to effectuate the intent of this Agreement (the "SCOPE OF WORK"). **[Attach a description of all of the obligations of the Services Provider as Exhibit C. You may use, as a starting point, the bid specifications, the Request for Proposals requirements, or the scope of work prepared by the Services Provider in his response to the RFP. Make sure that the Scope of Work includes each obligation of Services Provider described in #6--CTW.]** The Services Provider shall not perform any task that is not required by this Agreement or necessarily implied by it, without obtaining the prior written approval of the City. If the Services Provider chooses to perform any task without obtaining the City's prior written approval, the Services Provider does so at its own risk and expense.

1.9. If the City desires the Services Provider to perform additional tasks not set forth in the Scope of Work, the City will notify the Services Provider of that fact in writing ("SUPPLEMENTAL SERVICES"). If such changes cause a significant increase or decrease in the Services Provider's cost or time required for performance, the parties shall formally amend this Agreement. Any claim of Services Provider for adjustment under this clause must be asserted in writing within thirty (30) calendar days from the date of receipt by Services Provider of City's notice of changes, or such claim shall be deemed waived by Services Provider and Services Provider will be deemed to have agreed to the changes without modification of the compensation or time of performance hereunder. All such Supplemental Services shall be performed at the rates set forth in Exhibit D attached hereto and incorporated herein (the "SUPPLEMENTAL SERVICES RATES") **[Attach a copy of the Services Provider's current hourly rates for time and materials and attach as Exhibit D].**

1.10. The Services Provider shall at its own expense comply at all times with all municipal, county, state and federal laws, regulations, rules, codes, ordinances and other applicable legal requirements, including without limitation, the Americans with Disabilities Act, as such may be amended or modified from time to time (collectively, the "**LEGAL REQUIREMENTS**") in performing the Scope of Work for the Project.

A. In connection with the performance of work under this Agreement, the Services Provider agrees not to discriminate against any employee or applicant for employment because of race, creed, color, national origin, sex, sexual orientation, age, or any other protected class, including, without limitation, with regard to employment, upgrading, demotion or transfer, recruitment or recruitment advertising, layoff or termination, rates of pay or other forms of compensation, and selection for training, including, without limitation, apprenticeship.

1.11. The Services Provider shall at its own expense obtain and maintain in full force and effect at all times all necessary permits, licenses and other governmental approvals required by applicable Legal Requirements to be obtained and maintained by the Services Provider with respect to the Project, the Scope of Work and/or the business and operations of the Services Provider (collectively, the "**GOVERNMENTAL APPROVALS**"). In the event Services Provider is required to obtain any Governmental Approvals from the City in connection with the matters contemplated by this Agreement, the Services Provider acknowledges that the City will review Services Provider's applications for such Governmental Approvals in the ordinary course, and this Agreement shall not be deemed to be an approval of any such applications.

1.12. The Services Provider shall not commence performing any of its obligations under this Agreement until such time as it has received a Notice to Proceed from the City.

1.13 The Services Provider shall immediately notify the City if Services Provider becomes aware of any notice, citation, complaint or other matter issued by any governmental authority with respect to Services Provider, the Project or the Scope of Work, and shall not take any action to respond to or resolve same without receiving prior written approval from the City.

1.14 The Services Provider shall at its sole cost and expense obtain and maintain at all times the insurance required by Section 8, and shall promptly notify City if any such insurance is canceled or altered.

1.15 The Services Provider shall be responsible for maintaining satisfactory standards of employee competency, conduct and integrity, and shall be responsible for taking such disciplinary action with respect to its employees as may be necessary to maintain such standards. In the event that Services Provider fails to remove any employee from the Scope of Work whom the City deems incompetent, careless or insubordinate, or whose continued employment on the Scope of Work is deemed by the City to be contrary to the interests of the

City, the City reserves the right to require such removal as a condition for the continuation of this Agreement.

1.16 The Services Provider shall treat all information relating to the Project and all information supplied to the Services Provider by the City as confidential and proprietary information of the City and shall not permit its release by Services Provider's employees, agents or subcontractors to other parties or make any public announcement or release thereof without the City's prior written authorization. Services Provider shall also require its contractors, consultants and subcontractors, and their agents and employees to comply with this requirement.

1.17 Each employee, agent or subcontractor of Services Provider having access to personnel, data, information, personal property or real property of the City, must first submit to a background check performed by the City's Police Department, and must satisfactorily pass such background check, as determined by the City in its sole discretion, before performing any portion of the Project or the Scope of Work on behalf of Services Provider.

SECTION TWO RESPONSIBILITY OF CITY

In addition to any other obligations of City under this Agreement, the City has the following responsibilities:

2.1. The City will cooperate with the Services Provider in the performance of this Agreement and will be available for consultation with the Services Provider during normal City business hours.

2.2. In the event the City is required to review or respond to any submissions from the Services Provider, the City will conduct its review and/or provide its response within twenty-one days following receipt by the City of the Services Provider's submissions. The City's review of such submissions does not relieve the Services Provider for responsibility for the accuracy and completeness of such submissions and the conformance of such submissions to the requirements of this Agreement, including without limitation, the Scope of Work.

2.3. The City shall assemble selected data and information related to the Project and provide same to the Services Provider within _____ days after the date of this Agreement. The data and information to be provided by the CITY is the following:

A. **[INSERT all data and information to be provided by the City]**

B. The Services Provider shall be responsible for updating this data and information during the Project, and shall be responsible for acquiring supplemental data and information that the Services Provider deems necessary to complete the Scope of Work.

2.4. **[INSERT task by task all obligations of the City listed on #9--CTW]**

SECTION THREE PAYMENT TERMS

3.1 Subject to any provisions of this Agreement concerning payment, the City shall pay the Services Provider for the entirety of the Scope of Work the amount of Dollars (\$_____) (the "CONTRACT PRICE"), which amount shall be paid pursuant to this Section 3 **[choose as applicable from CTW #7--[in one lump sum on (insert date)] OR [in installments according to the following schedule--insert installment schedule from #7 of the CTW]]**

3.2 Payment to the Services Provider shall be made within thirty (30) calendar days after the City receives each invoice provided by the Services Provider to the City, provided that such invoice is complete, correct, and undisputed by the City, and that it contains the following information: **[insert information you want to see on the invoice]**

3.3 The CITY shall have fourteen (14) calendar days after receipt of an invoice to dispute any or all of the charges on the invoice. Disputed amounts shall be resolved through the Dispute Resolution mechanism in Section 11.

3.4 The Services Provider shall submit invoices only once per month, covering work performed by Services Provider or its agents or employees in the prior month.

3.5 Services Provider shall promptly pay any amounts due to any employees, agents, subcontractors or anyone else performing any portion of the work for Services Provider, and in the event any of the foregoing liens any City property, Services Provider shall promptly and at its expense cause such liens to be removed.

SECTION FOUR ACCESS TO RECORDS

4.1 The Services Provider shall maintain books, records, documents and other evidence directly pertinent to its performance under this Agreement in accordance with generally accepted accounting principles and practices. The Services Provider shall also maintain the financial and other information and data used by the Services Provider in the preparation or support of all invoices of Services Provider, and a copy of such invoices. The City, or any of its duly authorized representatives, shall have access to such books, records, documents and other evidence for the purpose of inspection, audit and copying. The Services Provider will provide proper facilities for such access and inspection.

4.2 Audits conducted pursuant to this Section shall be in accordance with generally accepted auditing standards and established procedures and guidelines for the reviewing or audit agencies.

4.3 The Services Provider agrees to the disclosure of all information and reports resulting from access to records pursuant to Section 4.1 above, to any Project funding

agency provided that the Services Provider is afforded the opportunity for an audit exit conference and an opportunity to comment and submit any supporting documentation on the pertinent portions of the draft audit report.

4.4 Records pursuant to Section 4.1 above shall be maintained and made available during performance under this Agreement and until three (3) years from the date of final payment for the Project. In addition, those records which relate to any dispute resolution, litigation or appeal, or the settlement of claims arising out of such performance, or costs or items to which an audit exception has been taken, shall be maintained and made available until three (3) years after the date of resolution of such dispute, litigation, appeal, claim or exception. This Section 4.4 shall survive the completion of the Project and the termination or expiration of this Agreement.

4.5 The Services Provider agrees to include language substantially similar to the language of Sections 4.1 through 4.4 in all Services Provider subcontracts related to performance of services specified in this Agreement.

SECTION FIVE PUBLIC RECORDS

5.1 Pursuant to NRS § 239.010 and other applicable Legal Requirements, each and every document provided to the City is a "public record" open to inspection and copying by any person, except for those documents otherwise declared by law to be confidential. The City shall not in any way be liable to Services Provider for the disclosure of any public record. In the event City is required to defend an action with regard to a public records request for documents submitted by Services Provider, Services Provider agrees to indemnify, hold harmless, and defend City from all damages, costs, and expenses, including court costs and reasonable attorney's fees related to such public records request. This Section 5 shall survive the expiration or earlier termination of this Agreement.

SECTION SIX FISCAL FUNDING OUT

6.1 City reasonably believes that sufficient funds can be obtained to make all payments during the term of this Agreement. Pursuant to NRS Chapter 354, if City does not allocate funds to continue the function performed by Services Provider obtained under this Agreement, said Agreement will be terminated when appropriated funds expire.

SECTION SEVEN REPRESENTATIONS AND WARRANTIES

7.1 Services Provider hereby represents and warrants for the benefit of City, in addition to any other representations and warranties made in this Agreement, with the knowledge and expectation of City's reliance thereon, as follows:

A. Services Provider is a duly formed and validly existing ***[corporation][limited liability company][partnership][insert applicable type of other entity]*** and is in good standing pursuant to the laws of the State of ***___[insert name of state where entity was formed]*** ***[INSERT LANGUAGE FOLLOWING COLON IF THE COMPANY WAS FORMED OUTSIDE OF NEVADA; and is duly qualified to do business in, and is in good standing in, Nevada]***, and has the full power, authority and legal right to execute, deliver and perform under this Agreement.

B. The execution and delivery of this Agreement, the consummation of the transactions provided for herein, and the fulfillment of the terms hereof on the part of Services Provider will not result in a breach of any instrument to which Services Provider is a party or by which Services Provider is bound or of any judgment, decree or order of any court or governmental body or any Legal Requirement applicable to Services Provider.

C. The execution, delivery and performance of this Agreement and the taking of all other lawful actions necessary to consummate the Project contemplated hereunder, by the persons executing, delivering and performing the same on behalf of Services Provider, have been duly and validly authorized (and by their execution hereof or of any document delivered in connection with the Project contemplated hereunder such persons individually represent and warrant that they are so authorized), and this Agreement and the other Agreements and instruments contemplated hereby, constitute legal, valid and binding obligations of Services Provider, enforceable in accordance with their respective terms.

D. No consent, approval or authorization of any governmental authority or private party is required in connection with the execution and performance of this Agreement by Services Provider.

E. Services Provider has obtained any and all Governmental Approvals that are required to be obtained by Services Provider by all Legal Requirements applicable to Services Provider and to the performance of the Scope of Work by Services Provider.

F. Services Provider is duly licensed and authorized to do business in the City, and Services Provider's business license is in full force and effect.

G. Services Provider is a sophisticated and qualified provider of the Services required by the Scope of Work, and its personnel possess the level of professional expertise and experience that is necessary to properly perform the Scope of Work within the Project Schedule and pursuant to the Budget, with an appropriate level of diligence, skill and care, and pursuant to the terms, specifications and conditions of this Agreement. Services Provider has the necessary personnel, equipment, tools, supplies, materials, and facilities to properly perform the Scope of Work within the Project Schedule and pursuant to the Budget, with an appropriate level of diligence, skill and care, and pursuant to the terms, specifications and conditions of this Agreement.

H. Services Provider is financially solvent, able to pay its debts as they mature, and possessed of sufficient working capital to complete the Project within the Project Schedule and pursuant to the Budget, and to perform all of its obligations under this Agreement.

I. Services Provider shall require that each subcontractor performing any portion of the Project or the Scope of Work:

1. Is duly formed, in good standing, and authorized to do business in the State of Nevada;
2. Has obtained any and all Governmental Approvals that are required to be obtained by all Legal Requirements applicable to the subcontractor and to the portion of the Project performed by subcontractor;
 - a) Shall be required to comply with all obligations of Services Provider to City under this Agreement;
 - b) Shall submit the names of all its employees, agents, or other persons performing any portion of the Scope of Work or the Project on behalf of subcontractor to the City for a background check, and shall staff its portion of the Project with those who have passed the background check to the City's satisfaction
5. Is duly licensed and authorized to do business in the City, and such business license is in full force and effect; and
6. Shall comply with all applicable Legal Requirements that are applicable to subcontractor and any portion of the Project work performed by subcontractor.

J. No person or entity has been employed or retained to solicit or secure this Agreement upon an agreement or understanding for a commission, percentage, brokerage or contingent fee. For breach of this warranty, the City shall have the right to annul this Agreement without liability or, in its discretion, to deduct from the Contract Price, or otherwise recover, the full amount of such commission, percentage, brokerage or contingent fee.

7.2 The representations and warranties made by Services Provider herein shall survive the completion of the Project and the termination or expiration of the Agreement.

SECTION EIGHT INSURANCE

8.1 Services Provider shall procure and maintain, and shall cause each subcontractor to procure and maintain at all times during the performance of the Project and for one year thereafter, at its own expense, the following insurances:

A. Workman's Compensation Insurance as required by applicable Legal Requirements, covering all persons employed in connection with the matters contemplated hereunder and with respect to whom death or injury claims could be asserted against City or the Services Provider.

B. Comprehensive General Liability (bodily injury and property damage) insurance in a policy limit of not less than [\$1,000,000—ask Dwight] for combined single limit per occurrence. Such General Liability insurance policy shall be endorsed as to include the City as an additional insured.

C. [If applicable] Professional Liability insurance, for the protection from claims arising out of performance of professional services caused by a negligent act, error, or omission for which the insured is legally liable; such Professional Liability insurance will provide for coverage in an amount of not less than [\$1,000,000—see Dwight] for each occurrence and [\$2,000,000—see Dwight] in the aggregate.

D. Automobile Liability insurance with a combined single limit of [\$1,000,000—see Dwight] per accident.

E. Employer's Liability insurance with limits of [\$1,000,000—see Dwight] per occurrence.

F. [Insert any other applicable insurance coverages, as appropriate. See #12—CTW and consult with Dwight and the City Attorney's office]

8.2 Certificates of Insurance indicating that such insurance is in effect shall be delivered to the City before work is begun under this Agreement. If the Services Provider is underwritten on a claims-made basis, the retroactive date shall be prior to or coincident with the date of this Agreement, and the Certificate of Insurance shall state that coverage is claims-made and the retroactive date. Services Provider shall provide the City annually with a Certificate of Insurance for each type of insurance required hereunder. It is further agreed that the Services Provider and/or Insurance Carrier shall provide the City with 30-day advance written notice of policy cancellation of any insurance policy required to be maintained by Services Provider.

8.3 All insurance policies required hereunder, and all renewals thereof, shall be provided by a company or companies authorized to do business in Nevada and having a A.M. Best rating of A:+ or higher, and shall expressly:

A. Provide that such policies shall not be cancelled or altered without thirty (30) days prior written notice to City; and

B. Waive subrogation against the City, its officers, agents, servants and employees; and

C. Provide that they are primary and noncontributing with any insurance which City may carry; and

D. Include or be endorsed to cover Services Provider's contractual liability to the City; and

E. Be signed by a person authorized by that insurer and licensed by the State of Nevada; and

F. Disclose all deductibles and self-insured retentions in the Certificate of Insurance. No deductible or self-insured retention may exceed \$250,000 without the written approval of the City.

SECTION NINE EVENT OF DEFAULT

9.1 As used herein, "City Event of Default" means any willful or intentional misconduct, fraud, or misrepresentation by City, or any breach of this Agreement, which City fails to remedy within five (5) days after written notice thereof to City, in the case of an event which can be cured by the payment of a sum of money, or within fifteen (15) days after written notice thereof to City, in the case of any other event; provided however, that if such non-monetary event is susceptible of cure but cannot reasonably be cured within such 15-day period, and City shall have commenced to cure such event within such 15-day period and thereafter diligently and expeditiously proceeds to cure the same, such 15-day period shall be extended for an additional period of time as is reasonably necessary for City in the exercise of due diligence to cure such event, which additional period of time shall in no event exceed six months.

9.2 As used herein, "Services Provider Event of Default" means any willful or intentional misconduct, fraud, or misrepresentation by Services Provider, or any breach of this Agreement, which Services Provider fails to remedy within five (5) days after written notice thereof to Services Provider, in the case of an event which can be cured by the payment of a sum of money, or within fifteen (15) days after written notice thereof to Services Provider, in the case of any other event; provided however, that if such non-monetary event is susceptible of cure but cannot reasonably be cured within such 15-day period, and Services Provider shall have commenced to cure such event within such 15-day period and thereafter diligently and expeditiously proceeds to cure the same, such 15-day period shall be extended for an additional period of time as is reasonably necessary for Services Provider in the exercise of due diligence to cure such event, which additional period of time shall in no event exceed two months.

9.3 A breach of this Agreement includes without limitation the following:

A. If Services Provider is unable to obtain or maintain any Governmental Authorizations necessary to perform its obligations under this Agreement;

B. If Services Provider shall be or become insolvent, voluntarily or involuntarily, or if Services Provider shall compound Services Provider's debts, or if any sheriff, marshal, constable, or any other officer takes possession of the Premises by virtue of any execution or attachment, or if any receiver, liquidator or trustee is appointed for Services Provider's property, or in the event Services Provider shall be adjudged a bankrupt, or if Services Provider makes an assignment for the benefit of creditors, or if Services Provider files a petition under any chapter of the Bankruptcy Act;

C. If Services Provider assigns or attempts to assign this Agreement without the City's prior written consent;

D. If Services Provider fails to provide the City with proof of insurance coverage as required by this Agreement;

E. If any financial statement, resume, statement of qualifications or representations and warranties of Services Provider, given to City by Services Provider, was materially false when given.

SECTION TEN TERMINATION

10.1 The City may terminate this Agreement at any time without cause upon notice to the Services Provider, and the City shall have no liability to Services Provider for such termination except that the City shall pay Services Provider for the reasonable value of Services provided by Services Provider to City up through and including the date of termination, provided that the Services Provider, within thirty (30) days following the date of the City's termination notice, submits an invoice for such Services in a form reasonably acceptable to the City and such invoice is supplemented by such underlying source documentation as is reasonably requested by the City.

10.2 The City may, upon written notice to Services Provider, terminate this Agreement immediately "for cause" upon a Services Provider Event of Default.

10.3 The Services Provider may, upon written notice to the City, terminate this Agreement immediately "for cause" upon a City Event of Default.

10.4 Either party may terminate this Agreement pursuant to any term of this Agreement which gives such party a right of termination.

SECTION ELEVEN DISPUTE RESOLUTION

11.1 All disputes between City and Services Provider shall be resolved in the following manner:

A. The City's representative and the Services Provider's Responsible Person will endeavor to conduct good faith negotiations in an effort to resolve any and all disputes in a timely manner.

B. If any disputes between the parties remain unresolved after fifteen (15) calendar days, the City's representative and the Services Provider's Responsible Person shall, within fourteen (14) calendar days, prepare a brief, concise written report summarizing the basis for the dispute, the negotiations accomplished and results thereof, and the current status of all relevant unresolved issues.

C. Copies of each written summary shall be exchanged between the City's representative and the Services Provider's Responsible Person, and provided to the City's Assistant City Manager, or his or her designee. Within fifteen (15) calendar days thereafter, the City's Assistant City Manager, or his or her designee, and the Services Provider's Responsible Person will meet to resolve the dispute. A written record of these negotiations will be made. The record will summarize all issues of dispute, the resolutions to resolved issues, and unresolved issues, if any.

D. If there are still unresolved issues, the written record will be reviewed by the City's City Manager, or his or her designee, who will render a determination regarding such dispute. Such determination will be the final administrative determination.

E. If the Services Provider disagrees with the determination of the City's City Manager, or his or her designee, the Services Provider may only initiate an action in the Eighth Judicial District Court in and for Clark County to resolve such dispute. The City retains the right to all remedies available at law or in equity. The Parties agree that no dispute under this Agreement shall be submitted to or resolved through arbitration or mediation.

SECTION TWELVE INDEMNIFICATION

12.1 Notwithstanding any of the insurance requirements herein above set forth or limits of liability set forth therein, Services Provider shall defend, protect, indemnify and hold harmless the City, and its officers, agents and employees, from any liabilities, claims, damages, losses, expenses, proceedings, suits, actions, decrees, judgments, reasonable attorney fees, and court costs which the City suffers, and/or its officers, agents or employees suffer, as a result of, or arising out of, the negligent or intentional acts or omissions of the Services Provider, its subcontractors, agents, and employees, or anyone employed by any of them, in fulfillment or performance of the terms, conditions or covenants of this Agreement. This Section 12 shall survive the completion of the Project and the termination or expiration of this Agreement until such time as the applicable statutes of limitation expire.

14.5 Partial Invalidity. If any term, provision, covenant or condition of this Agreement, or any application thereof, should be held by a court of competent jurisdiction to be invalid, void or unenforceable, all provisions, covenants, and conditions of this Agreement, and all applications thereof, not held invalid, void or unenforceable, shall continue in full force and effect.

14.6 Attorneys' Fees. In the event any action is commenced by either party against the other in connection herewith (including any action to lift a stay or other bankruptcy proceeding), the prevailing party shall be entitled to its costs and expenses, including reasonable attorneys' fees, as determined by the court. This Section 14.6 shall survive the completion of the Project until the applicable statutes of limitation expire.

14.7 Entire Agreement. This Agreement constitutes the entire Agreement between the parties pertaining to the subject matter contained herein and supersedes all prior representations, agreements and understandings of the parties. No addition to or modification of this Agreement shall be binding unless executed in writing by the parties hereto.

14.8 Time of Essence. Time is of the essence in the performance of this Agreement and all terms, provisions, covenants and conditions hereof.

14.9 Ownership of documents. All plans, drawings, specifications, reports, photographs, studies, permits, estimates, digital mapping, CAD files, mylar, **[List all other documents prepared in your transaction]** or other like documents given, prepared or assembled by the Services Provider or any subcontractor that are related to the performance of this Agreement are deemed to be a "Work made for Hire" and are the property of the City, except to the extent such is not allowed by applicable Legal Requirements.

14.10 No Brokers. City and Services Provider each represent and warrant that neither of them has dealt with a broker or otherwise agreed to pay a broker's or agent's commission, finder's fee or other like compensation to anyone in connection with this Agreement, and Services Provider and City each agrees to indemnify, defend and hold the other party harmless from and against such claims or costs, including reasonable attorneys' fees, if the indemnifying party has wrongly made this representation and warranty. This Section 14.10 shall survive the expiration or earlier termination of this Agreement.

14.11 Headings. The paragraph headings of this Agreement have been inserted only for convenience, and shall not be deemed in any manner to modify or limit any of the provisions of this Agreement, or be used in any manner in the interpretation of this Agreement.

14.12 Interpretation. Whenever the context so requires, all words used in the singular shall be construed to have been used in the plural (and vice versa), each gender shall be construed to include any other genders, and the word "person" shall be construed to include a natural person or any other entity. The words "include" or "including" shall be deemed to incorporate "without limitation".

14.13 No Joint Venture. This Agreement is not intended to create, and shall not be deemed to create, any relationship between the parties hereto other than that of independent entities contracting with each other solely for the purpose of effecting the provisions of this Agreement. Neither of the parties hereto shall be construed to be the agent, employer, representative or joint venturer of the other.

14.14 Further Assurances. Buyer and Seller shall each execute and deliver all such documents and perform such acts as are reasonably requested by the other party to effectuate the transactions contemplated by this Agreement, provided that such further assurances are provided by each party at no additional cost to such party and are otherwise consistent with the terms and intent of this Agreement.

14.15 Construction. This Agreement shall not be construed more strictly against one party than against the other, merely by virtue of the fact that it may have been prepared primarily by counsel for one of the parties, it being recognized that both parties have contributed substantially and materially to the preparation of this Agreement.

14.16 Effect of Agreement Termination. In the event this Agreement is terminated, all rights and obligations of the parties hereunder shall cease, other than indemnity obligations and matters that by their terms survive the termination hereof.

14.17 Force Majeure. In the event any party is unable to perform its obligations under this Agreement because of a Force Majeure Event, then such party shall provide the other party with notice of its inability to perform its obligations hereunder, together with documentation supporting the existence of such Force Majeure Event, and shall promptly begin to perform, or resume performance of, its obligations under this Agreement upon the cessation of the Force Majeure Event. As used herein, a "Force Majeure Event" means labor strikes, extraordinary civil commotion, war, warlike operation, fire or other casualty, inability to obtain fuel or energy, unusual or uncustomary weather conditions, or other acts of God, or other causes beyond a party's reasonable control (financial inability excepted).

IN WITNESS WHEREOF, the City and the Services Provider have caused this Agreement to be executed as of the day and year first above written.

City of North Las Vegas

[Services Provider Name]

By: _____
Michael L. Montandon, Mayor

By: _____
**[Type Name and Title of Person
Executing Document]**

Attest:

By: _____
Karen Storms, City Clerk, CMC

Approved as to Form:

Carie A. Torrence, City Attorney

By:

Deputy City Attorney

Exhibit A

Project Schedule

Exhibit B

Budget

Exhibit C
Scope of Work

Exhibit D

Supplemental Services Rates